



## PN25 CENTRIFUGAL PUMPS CSP series



HYGIENE



BIOTECHNOLOGY



INDUSTRIAL

*Close-coupled centrifugal pumps with open impellers, built for specific uses in the food, beverage and water treatment industries.*

*Designed for uses involving high suction pressure thanks to the casing made from solid steel, the forged cover and the reinforced clamp.*

*Parts in contact with the product made from CF3M 1.4404 / AISI 316L stainless steel.*

*Special finishes up to 0.5  $\mu$ m Ra are available on request.*

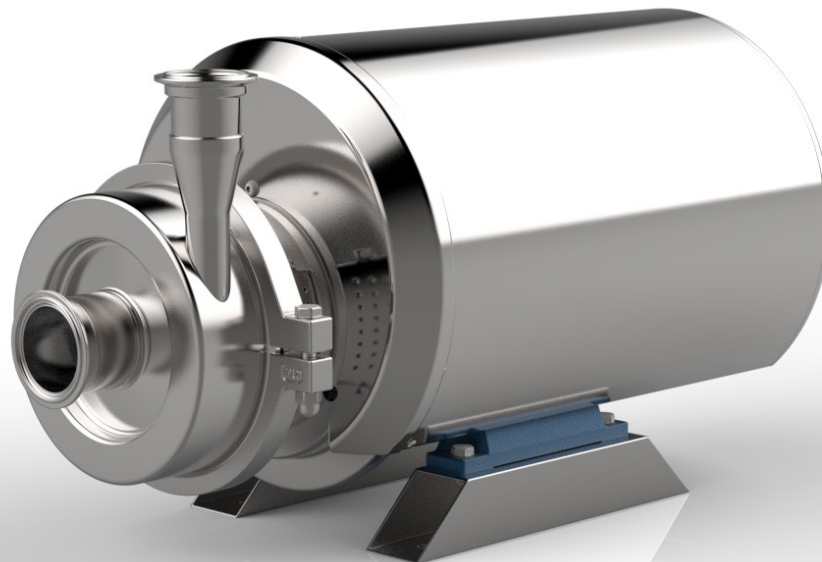

### Applications

*The CSP series pumps are suitable for numerous applications in the food, pharmaceutical, beverage and chemical industries; in particular in applications requiring high suction pressures:*

- pasteurization in beer plants;*
- whey dewatering, fruit juice concentration, enzyme selection and concentration, reduction of alcohol content in beer and wine;*
- ultrafiltration, nanofiltration and reverse osmosis systems for water demineralization and purification;*
- industrial wastewater treatment by membrane process.*

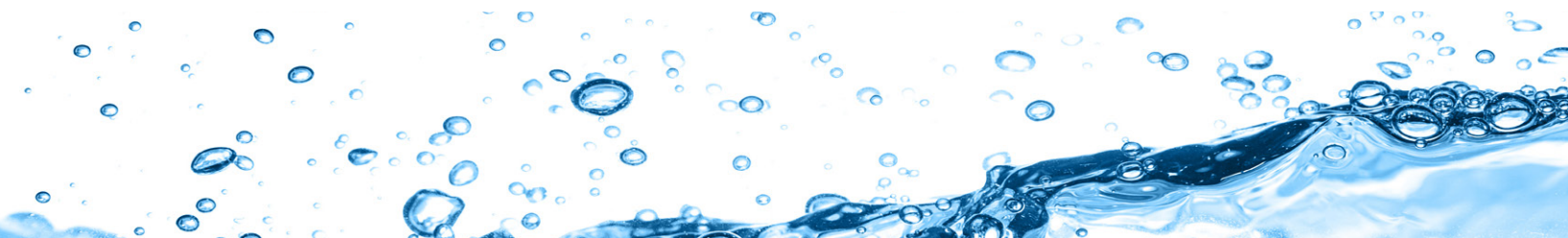

## CHARACTERISTICS

Close-coupled construction made entirely from stainless steel with independent motor, balanced internal mechanical seal and open impeller.

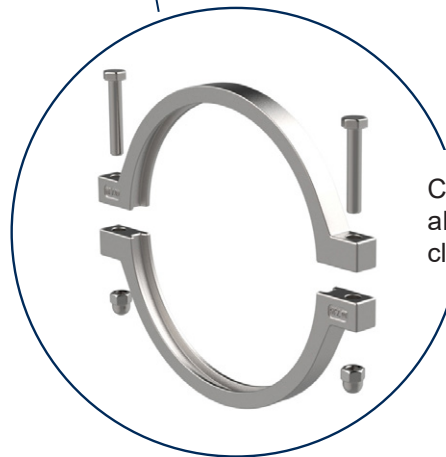
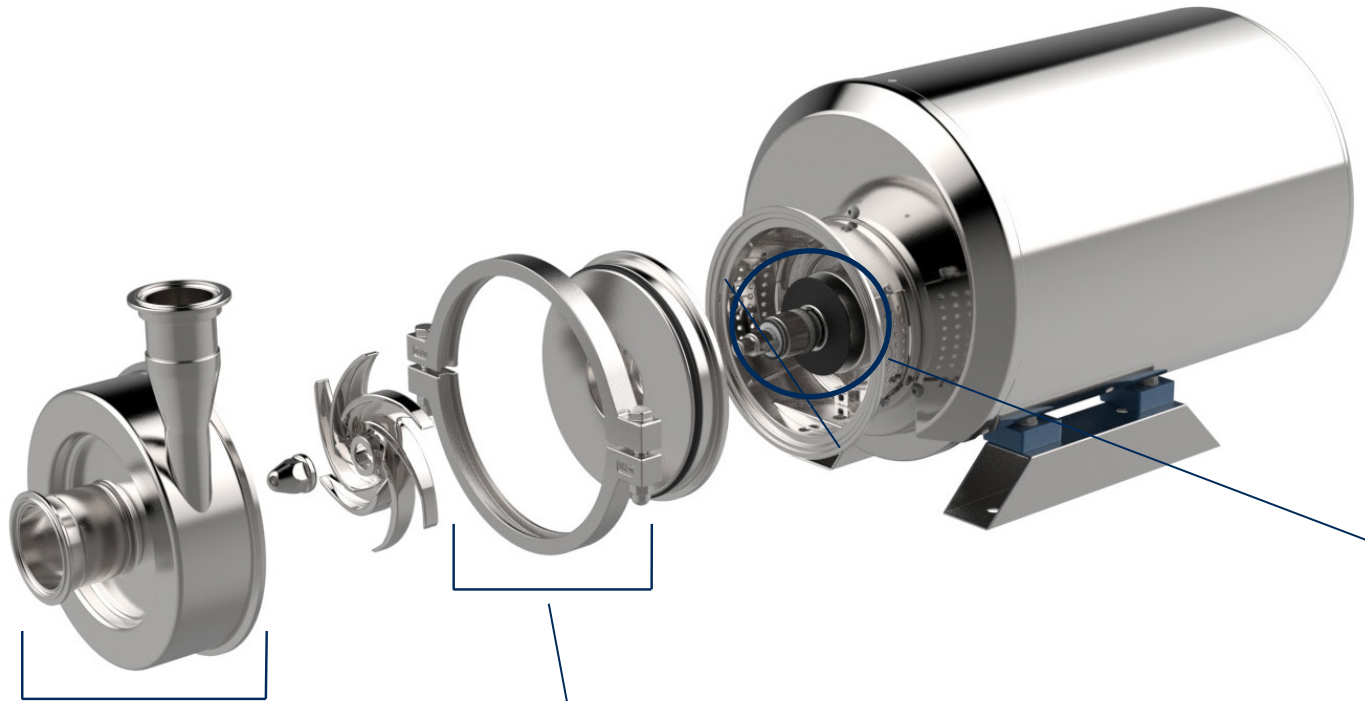

Casing closure by means of two saddles allows quick disassembly for inspection, cleaning and maintenance.

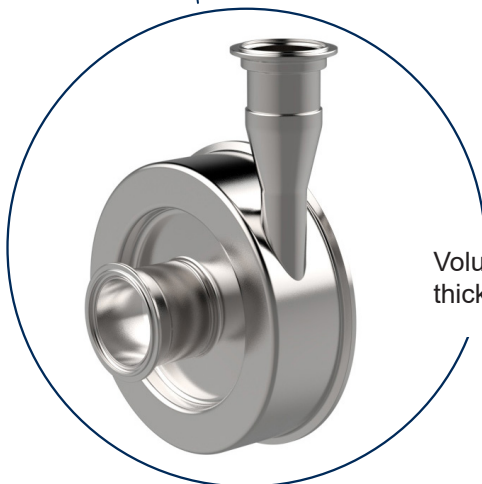

Volute pump casing with uniform circular section designed with thicknesses suitable for working at design pressures of 25 bar.

## TECHNICAL DATA

Flow rate up to 50 m<sup>3</sup>/h  
Head values up to 80 m  
Maximum operating pressure 25 bar  
Temperature range -10°C to +140°C.

### Seals:

Hygienic mechanical seals with seat standardized to EN 12756, ISO 3069 standards

### Connections:

Flanges EN 1092-1 PN 40, Clamp for high pressures, DIN 11851 up to 16 bar / 11864 up to 25 bar.

### Seal materials (FDA, Regulation (EC) No. 1935/2004):

Ethylene propylene (EPDM)  
Special Fluorocarbon  
Fluorocarbon seal (FPM - FKM)  
FFPM - FFKM

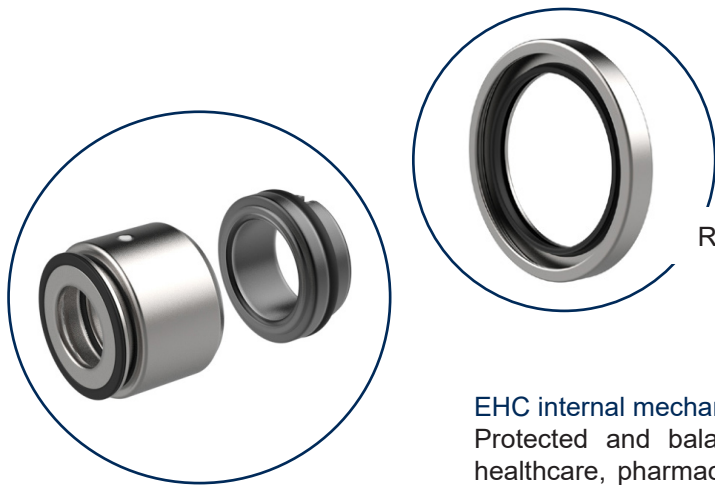

### EHC internal mechanical seal

Protected and balanced execution, easy to clean, ideal for food, healthcare, pharmaceutical uses, etc.. Also available with an external protection chamber and external flushing, consisting of an internal mechanical seal and an external radial seal (R).

### Independent support

Sturdy and modular for integration in various solutions.

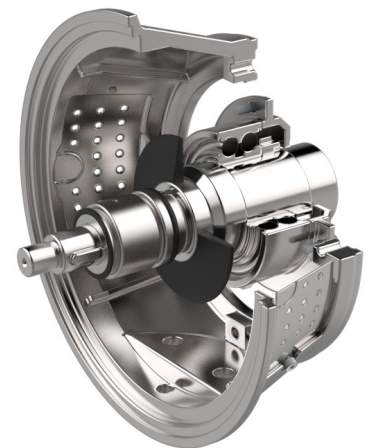

### Impeller

Each pump model has its own impeller. Manufactured with perfect shapes, thickness and materials and balanced thanks to the investment casting procedure. This means that they are perfectly efficient and reliable.



## OVERALL DIMENSIONS

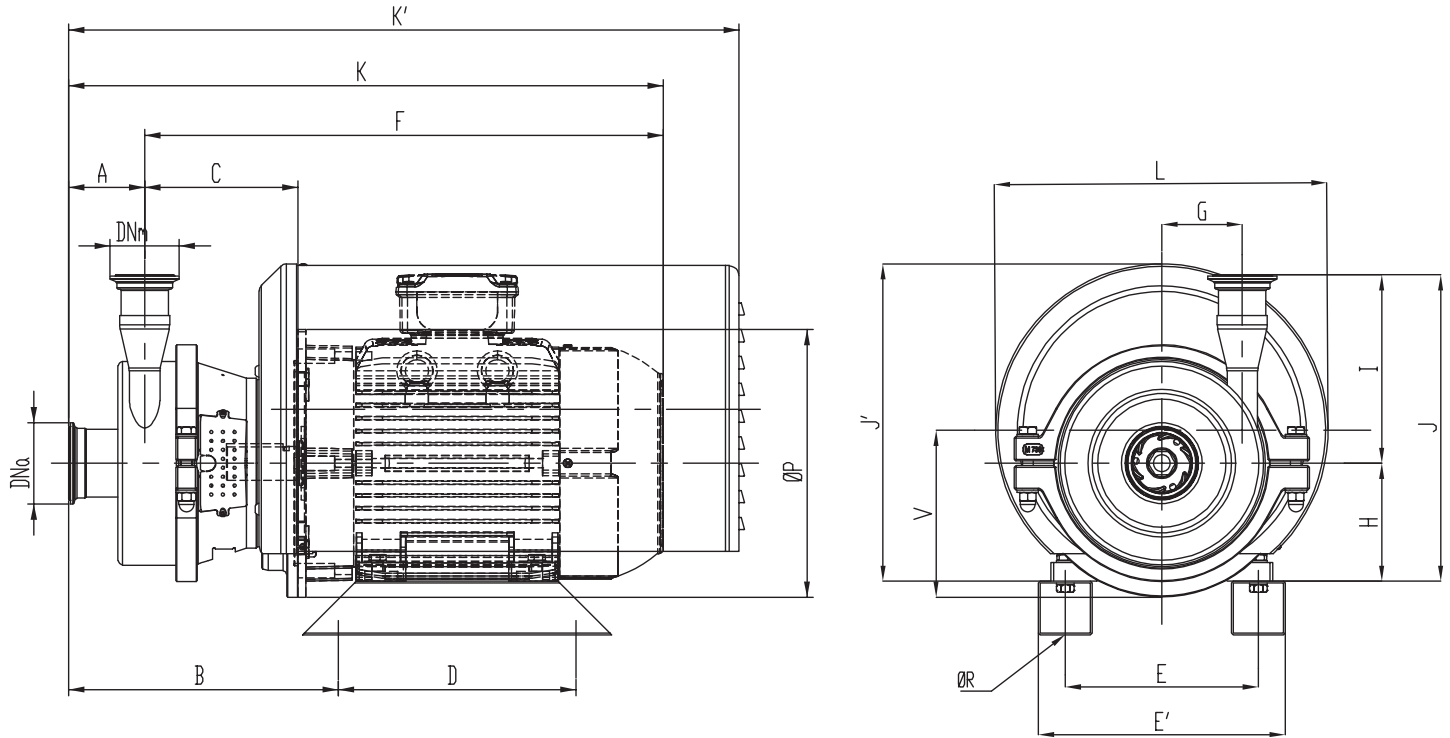

Dimensions not binding - DIN 11864-3A connection - exec. with standard IEC/EN motors

Pump type	Motor size	DNa	DNm	A	B	C	D	E	E'	F	G	H	K	K'	ØP	ØR	I	J	J'	L	V
CSP 40-175	IEC132	50	40	75	288,7	168,5	266	216	276	577	90	132	652	737,7	300	12	200,5	332,5	315	372	187
CSP 40-210	IEC160	50	40	75	369,7	231,5	330	254	314	761,8	115	160	836,8	961,5	350	14	215,5	375,5	480,7	480	230
CSP 50-175	IEC132	65	50	85	301,7	171,5	266	216	276	580	90	132	665	750	300	12	211	343	355	372	187
CSP 50-210	IEC160	65	50	85	380,7	231,5	330	254	314	761,8	115	160	847,8	972,5	350	14	266	386	458	480	230



**C.S.F. Inox S.p.A.** Strada per Bibbiano, 7 - 42027 Montecchio E. (RE) - ITALY EU  
 Ph +39.0522.869911 r.a. - Fx +39.0522.865454 - italia@csf.it - www.csf.it  
**Export Department • Commercial Étranger • Comercial Extranjero**  
 Ph +39.0522.869922 - Fx +39.0522.869841 - export@csf.it - www.csf.it



All indications, data and figures (in any form) shown in this publication are indicative and not binding. C.S.F. INOX does not assume any guarantee or obligation for the use of this document nor for the information contained herein. In particular, it does not guarantee against omissions or errors in the data and drawings provided. Please note that the technical data, information and images provided in this document are of a purely indicative and approximate nature. C.S.F. INOX reserves the right, at any time and without prior notice, to modify the data, drawings and information provided in this document.